



OWNERS MANUAL

Model No.

45-0414

45-0415

CAUTION:
Read Rules for
Safe Operation
and Instructions
Carefully

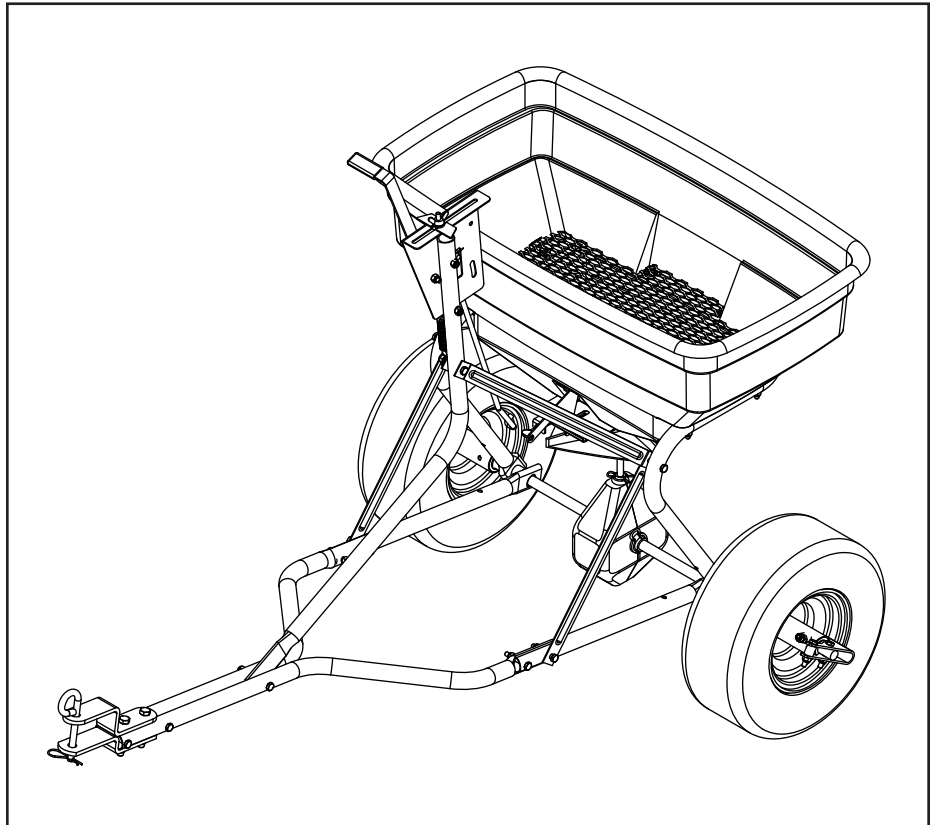

125 LB. TOW BROADCAST SPREADER

- Safety
- Assembly
- Operation
- Maintenance
- Parts

SpeedPart *the fastest way to purchase parts* www.speedepart.com

RULES FOR SAFE OPERATION

Any power equipment can cause injury if operated improperly or if the user does not understand how to operate the equipment. Exercise caution at all times when operating equipment.

- Read the towing vehicle owners manual and towing vehicle safety rules. Know how to operate your tractor before using the broadcast spreader attachment.
- Read the chemical label instructions and cautions for handling and applying the chemicals purchased for spreading.
- Wear eye and hand protection when handling and when applying lawn or garden chemicals.
- Never operate tractor and spreader attachment without wearing substantial footwear, and do not allow anyone to ride or sit on spreader attachment frame.
- Follow maintenance and lubrication instructions as outlined in this manual.
- Always begin with the transmission in first (low) gear and with the engine at low speed, and gradually increase speed as conditions permit.
- When towing broadcast spreader do not drive too close to a creek or ditch and be alert for holes and other hazards which could cause you to loose control of the broadcast spreader and tractor.
- Before operating vehicle on any grade (hill) refer to the safety rules in the vehicle owner's manual concerning safe operation on slopes. **Stay off steep slopes!**
- Never allow children to operate the tractor or spreader attachment, and do not allow adults to operate without proper instructions.

 **LOOK FOR THIS SYMBOL TO POINT OUT IMPORTANT SAFETY PRECAUTIONS. IT MEANS — ATTENTION! BECOME ALERT! YOUR SAFETY IS INVOLVED.**

CARTON CONTENTS

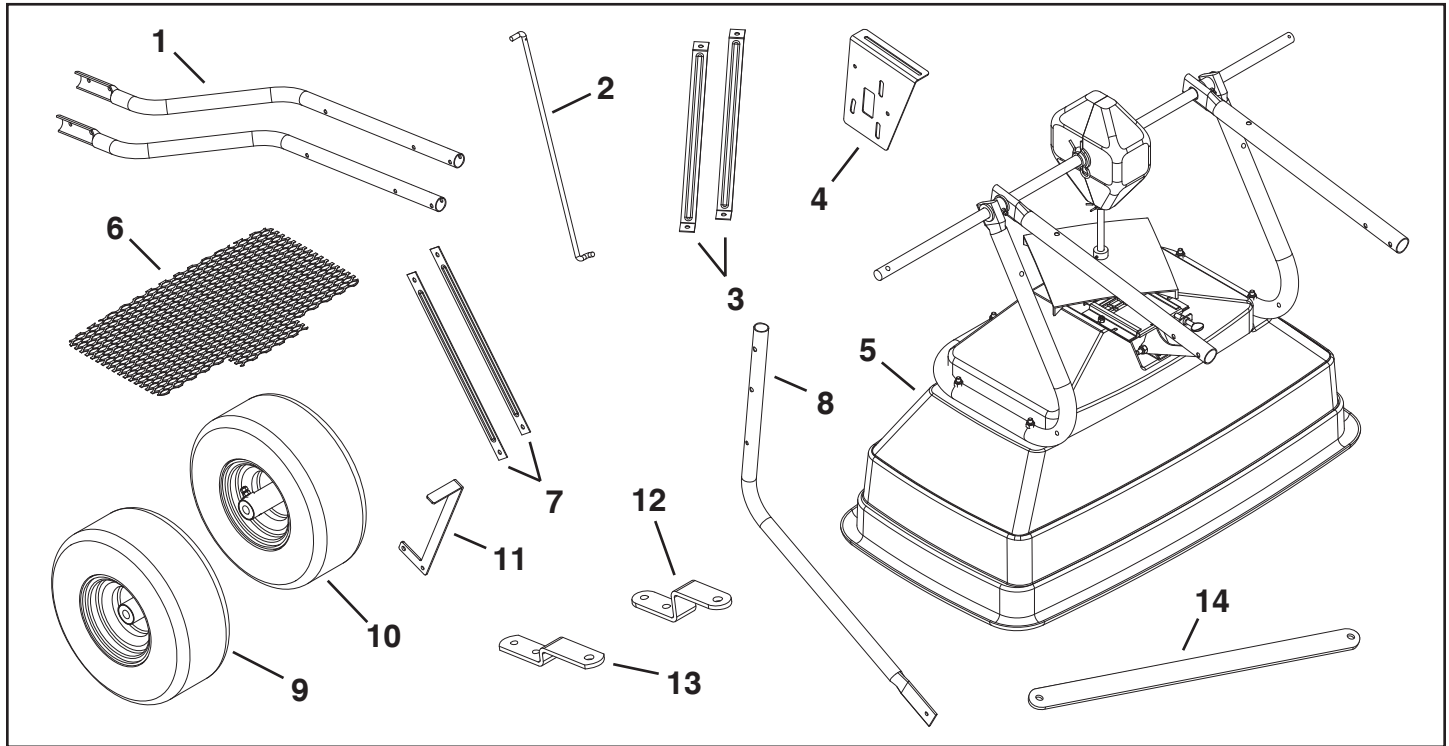

1	Drawbar Tube	8	Control Tube
2	Flow Control Rod	9	RH Wheel
3	Bent Hitch Brace	10	LH Wheel
4	Flow Control Bracket	11	Flow Control Arm
5	Hopper Assembly	12	Top Hitch (tall)
6	Hopper Screen	13	Bottom Hitch (short)
7	Straight Hitch Brace	14	Reinforcement Strap

HARDWARE PACKAGE

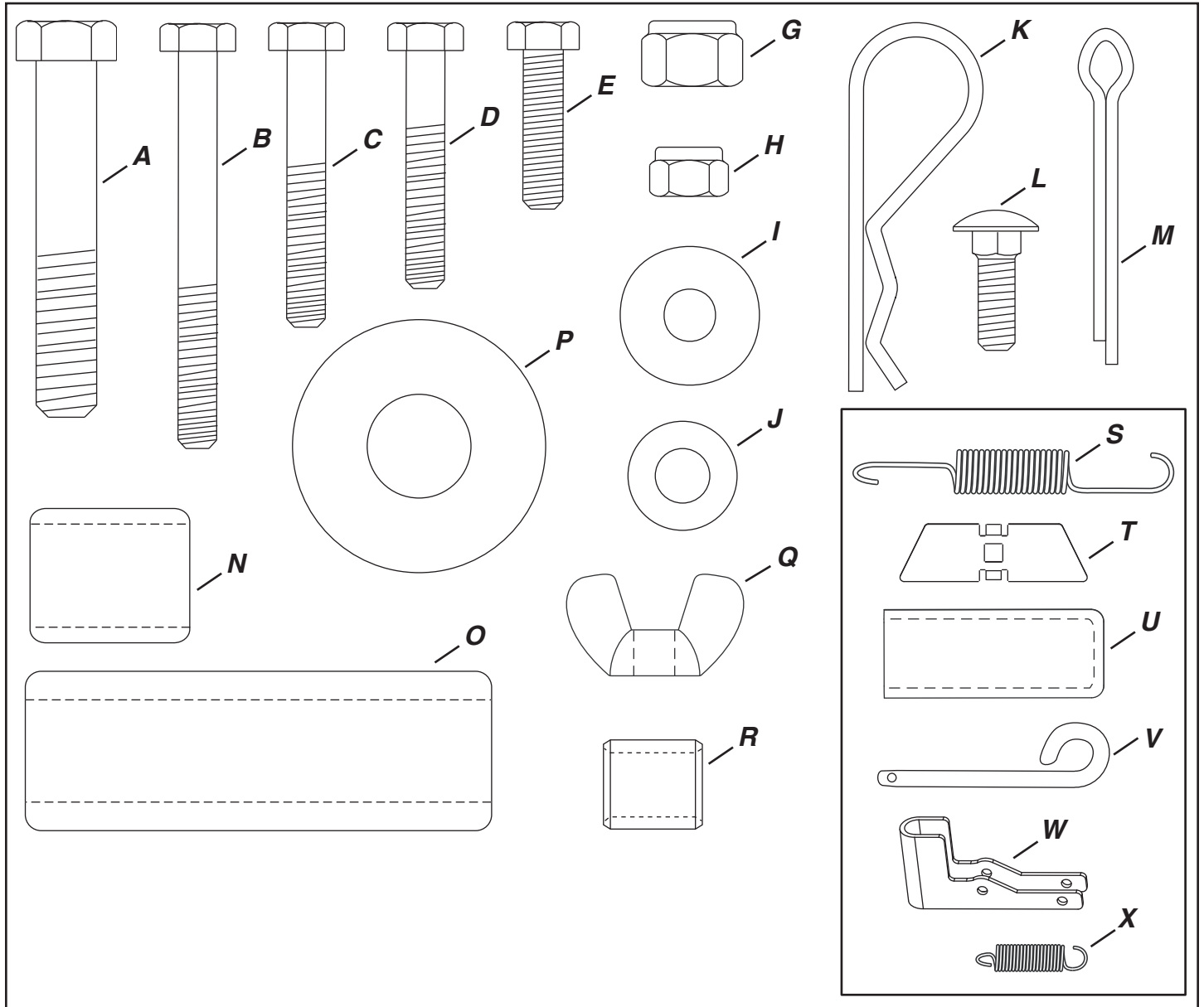

REF	QTY	DESCRIPTION	REF	QTY	DESCRIPTION
A	2	Hex Bolt, 3/8" x 2-1/4"	N	1	Spacer, .64 x .84 x 1
B	3	Hex Bolt, 1/4" x 2-1/2"	O	1	Spacer, .64 x 1 x 2.94
C	5	Hex Bolt, 1/4" x 1-3/4"	P	6	Washer, Large
D	8	Hex Bolt, 1/4" x 1-1/2"	Q	1	Wing Nut, 1/4"
E	1	Hex Bolt, 1/4" x 1"	R	1	Spacer, .39 x .56 x .62
G	2	Nylock Nut, 3/8"	S	1	Spring
H	18	Nylock Nut, 1/4"	T	1	Adjustable Stop
I	2	Nylon Washer	U	1	Grip
J	4	Washer, Small	V	1	Hitch Pin
K	1	Hair Cotter Pin	W	1	Engagement Bracket
L	1	Carriage Bolt, 1/4-20 x 3/4"	X	1	Spring
M	1	Cotter Pin, 9/64 x 1-1/2"			

ASSEMBLY INSTRUCTIONS

TOOLS REQUIRED FOR ASSEMBLY

- (1) Pliers
- (2) 7/16" Wrenches
- (2) 1/2" Wrenches
- (2) 9/16" Wrenches

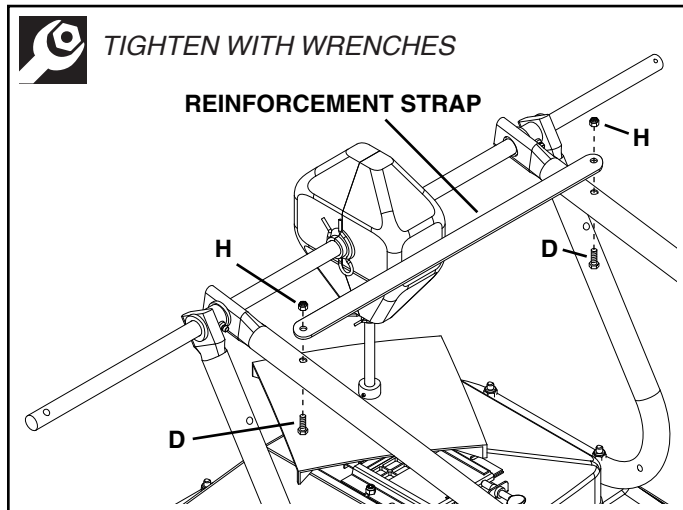

FIGURE 1

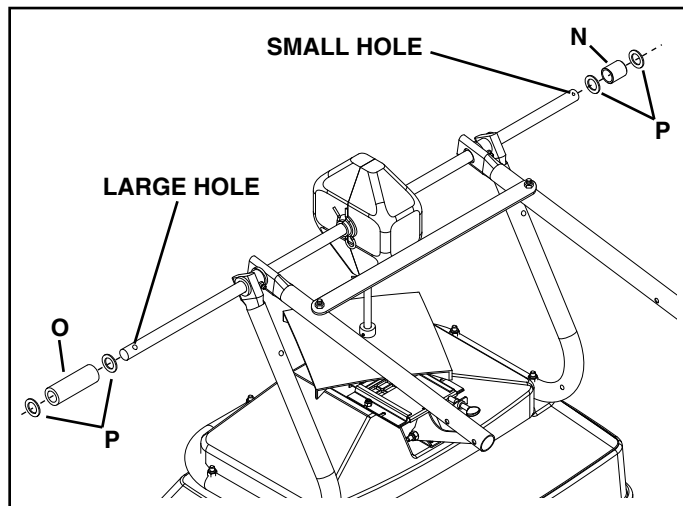

FIGURE 2

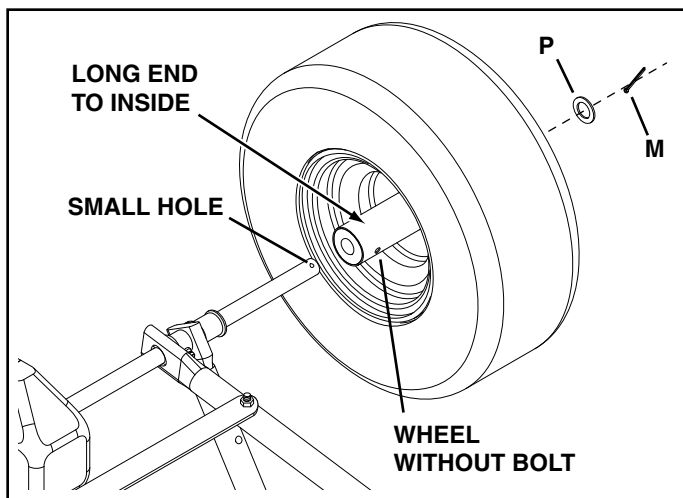

FIGURE 3

After assembling bracket (W) to axle, tighten both bolts. Loosen bolt through axle just enough that bracket (W) can pivot but will stay in place. See figure 4.

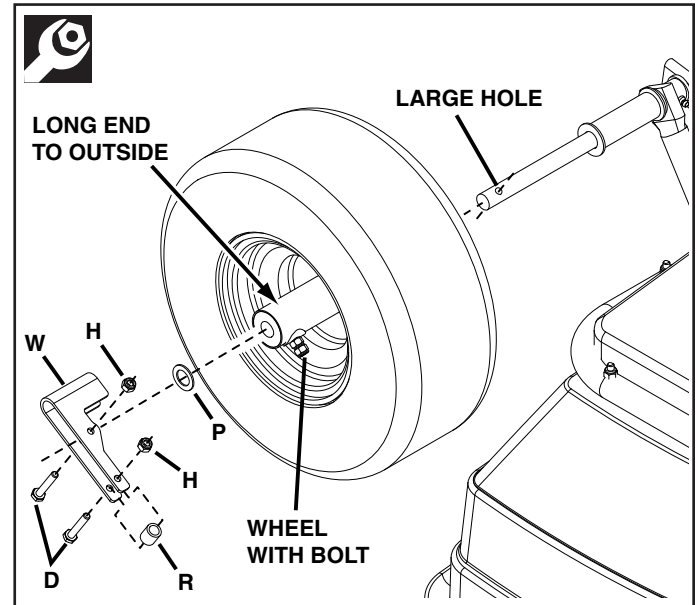

FIGURE 4

Assemble bent hitch braces and then straight hitch braces to inside of spreader frame. Straight hitch braces must be to inside of bent hitch braces. See figure 5.

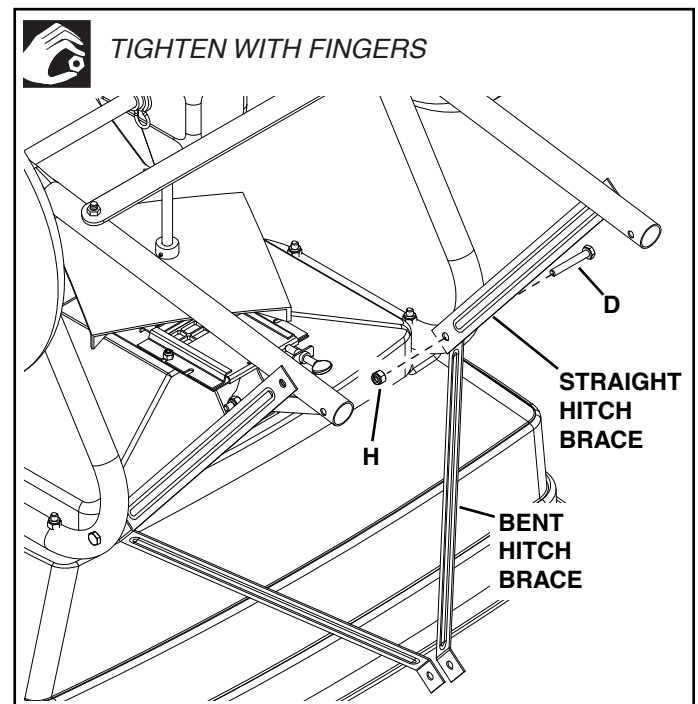

FIGURE 5

Assemble drawbar tubes to inside of lower handle tubes. Assemble straight hitch braces to outside of lower handle tubes. See figure 6.

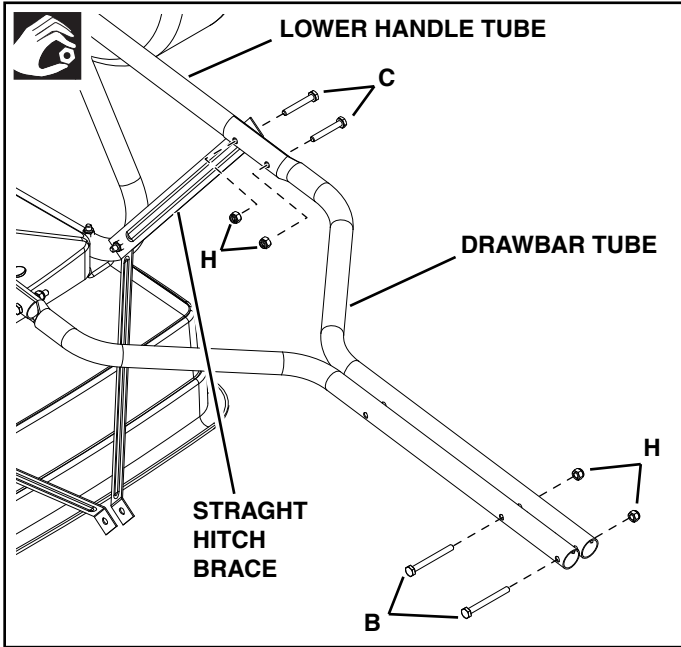

FIGURE 6

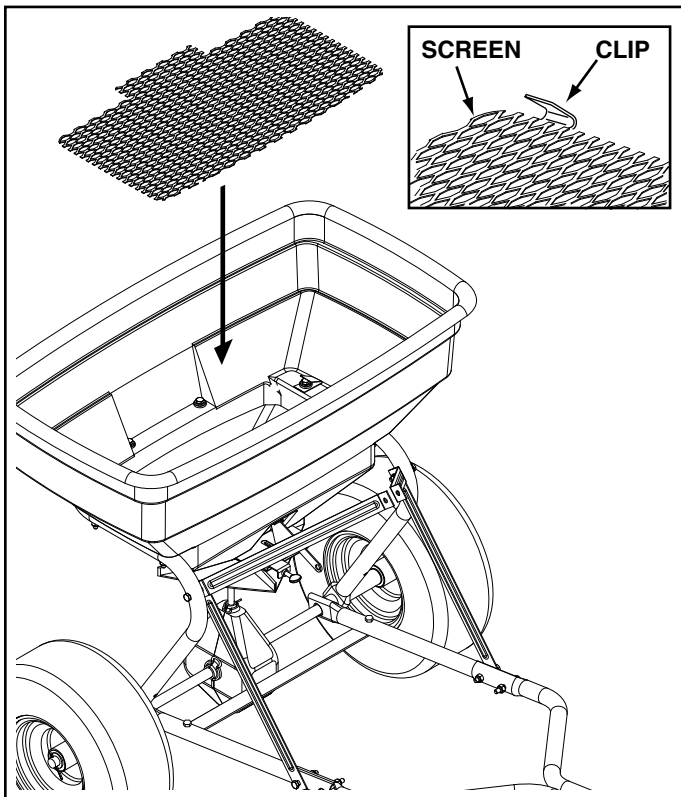

FIGURE 7

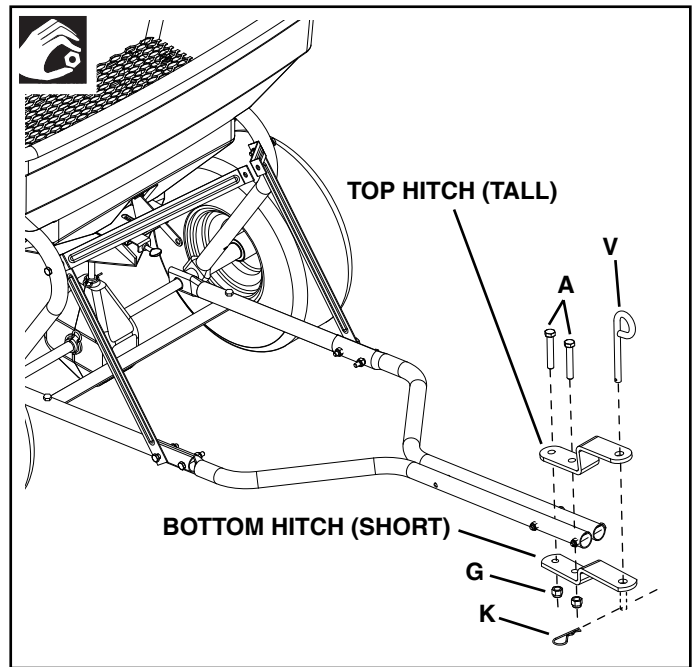

FIGURE 8

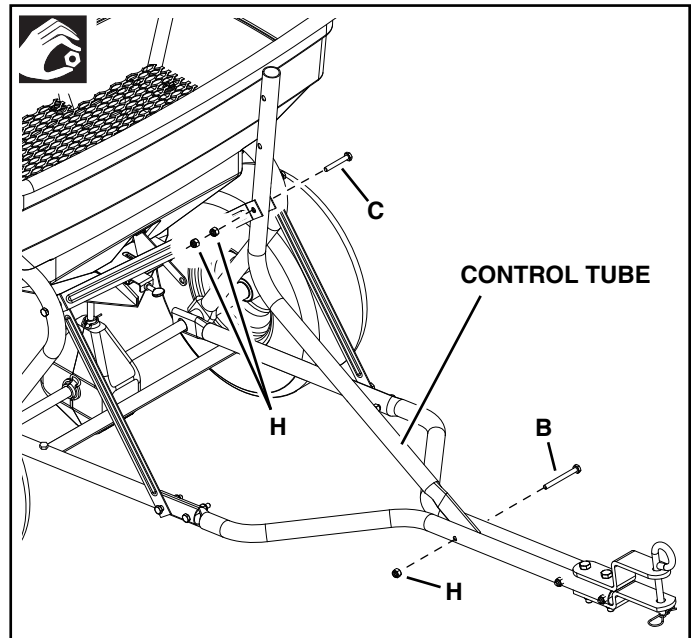

FIGURE 9

TIGHTEN FASTENERS

Tighten fasteners in the order below.

FIGURE 6 

FIGURE 8 

FIGURE 9 

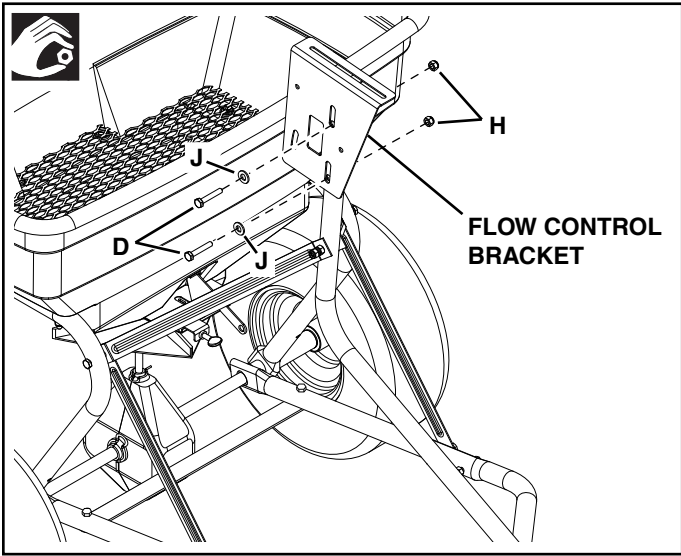

FIGURE 10

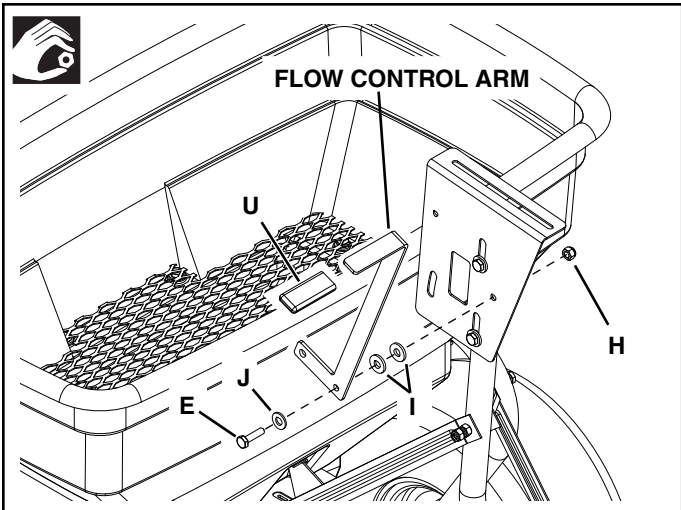

FIGURE 11

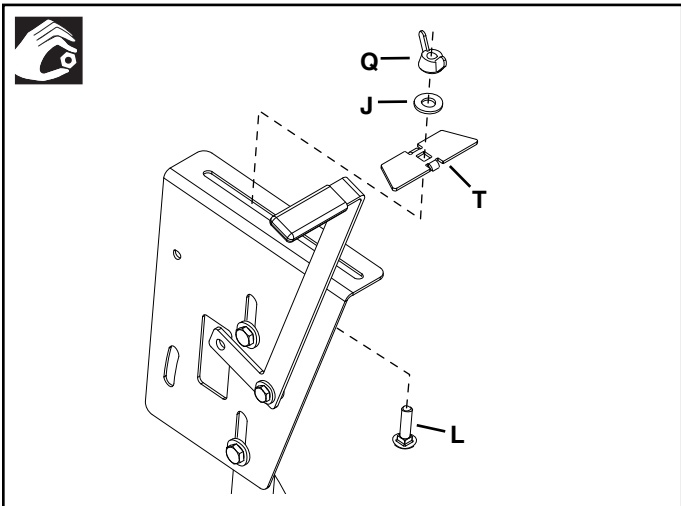

FIGURE 12

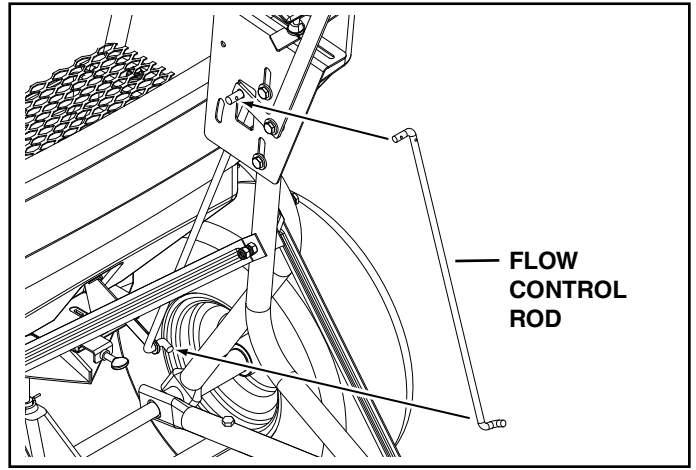

FIGURE 13

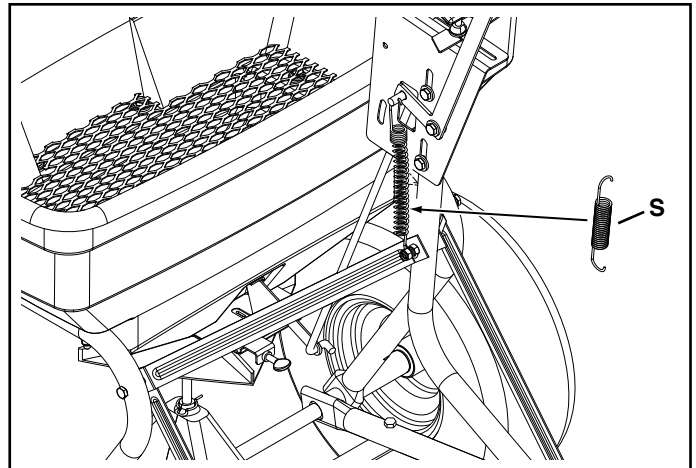

FIGURE 14

Slip the small spring (X) onto the end flow control rod and then attach it to the pattern plate. See figure 15.

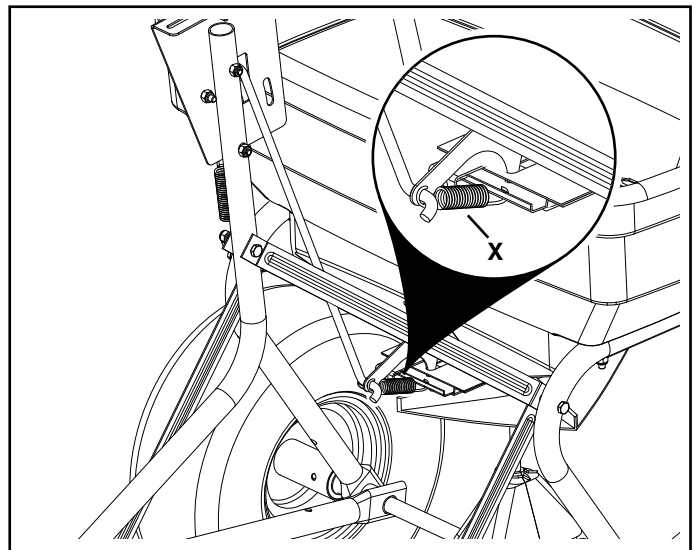



FIGURE 15

CONTINUE TO NEXT PAGE

TIGHTEN FASTENERS

FIGURE 11  Tighten the nut (H) and then loosen just enough that the flow control arm moves freely.

CALIBRATING FLOW CONTROL ARM

Flow control mounting bracket (figure 16 and 17)

- Set adjustable stop at "OFF" position. Move flow control arm against adjustable stop.
- Slide flow control mounting bracket along control tube until closure plate in bottom of hopper just closes.
- Snug the nuts just enough to hold flow control mounting bracket in place.
- Set adjustable stop at "5". With flow control arm resting against stop, verify that closure plate is open about half way.
- If closure plate is not open about half way, slide flow control mounting bracket up or down control tube until closure plate will open about half way at "5" and will close completely when arm is pushed past adjustable stop to "OFF" position. **Tighten** the 5/16" nylock hex nuts.

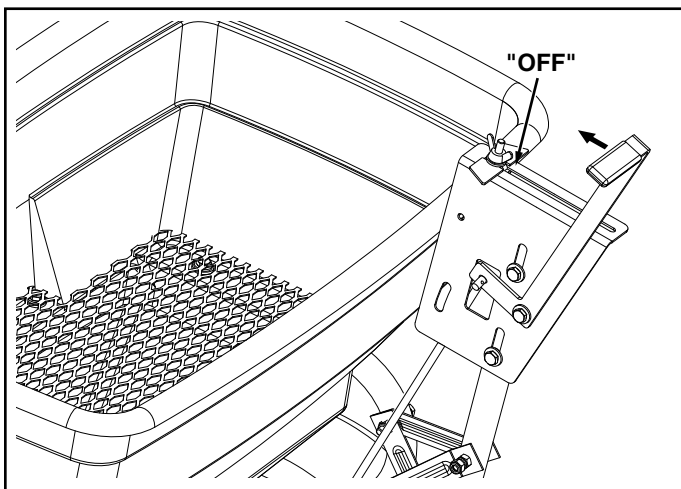

FIGURE 16

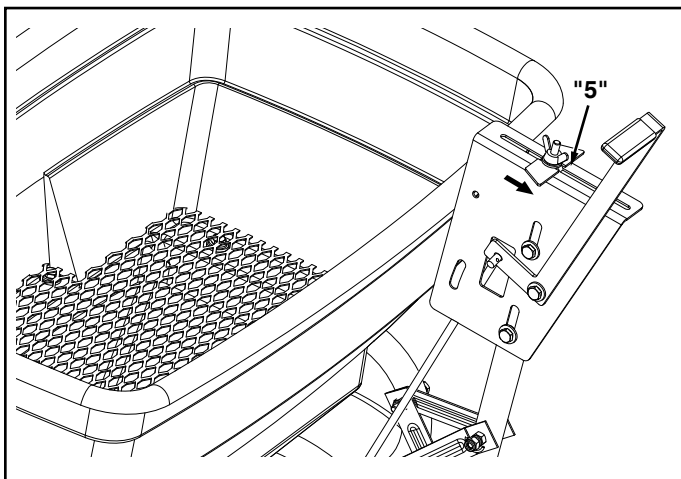

FIGURE 17

OPERATION

HOW TO USE YOUR SPREADER

SETTING THE FLOW CONTROL

(Refer to figure 16 and 17)

- Loosen the nylon wing nut, set the adjustable stop to the desired flow rate setting and retighten the wing nut. The higher the setting number, the wider the opening in the bottom of the hopper.
- Refer to the *Application Chart* on page 8 and to the instructions on the fertilizer bag to select the proper flow rate setting.
- Pull the flow control arm from the "OFF" position and rest it against the adjustable stop for the "ON" position. Push the flow control arm past the stop, toward the hopper for the "OFF" position.

USING THE PATTERN ADJUSTMENT PLATE

The pattern adjustment plate is used to adjust the flow of material being spread to the left or right side. The pattern adjustment plate is the bottom stainless steel plate underneath the hopper.

The adjustment of the pattern plate is sensitive. It is recommended that you test your spread pattern in a small area first.

- To adjust the flow to be heavier to the left side, tighten the thumbscrew so the plate will not pull out as far. See figure 18.
- To adjust the flow to be heavier to the right side, loosen the thumbscrew so the plate will pull out farther. See figure 18.

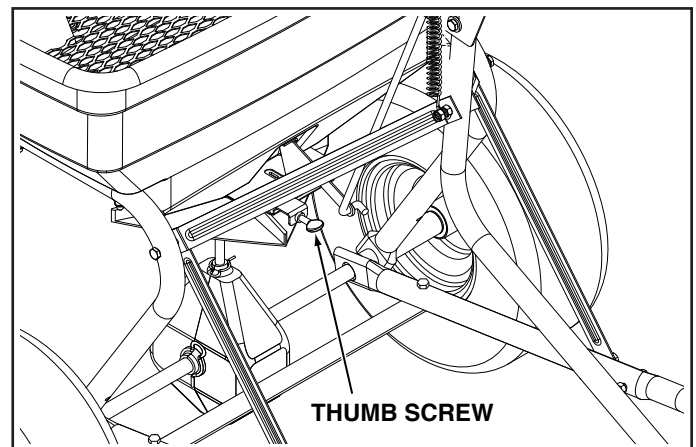

FIGURE 18

USING YOUR SPREADER

The use of powdered lawn chemicals is not recommended, due to difficulty in obtaining a satisfactory or consistent broadcast pattern.

1. Determine approximate square footage of area to be covered and estimate amount of material required.
2. Before filling the hopper, set the adjustable stop to the proper setting. Refer to the *Application Chart* on this page and to the instructions on the fertilizer bag to select the proper flow rate setting.
3. Move the flow control arm past the adjustable stop to the "OFF" position so that the closure plate is shut.
4. Fill the hopper, breaking up any lumpy fertilizer.
5. The *Application Chart* is calculated for light-to-heavy application at a walking speed of 3 mph, or 100 ft. in 23 seconds. A variation in speed will require an adjustment of the flow rate to maintain the same coverage. The faster you travel, the wider the broadcast width.
6. Always start the spreader in motion before opening the closure plate.
7. Always shut the closure plate before turning or stopping the spreader.
8. If fertilizer is accidentally deposited too heavily in a small area, soak the area thoroughly with a garden hose or sprinkler to prevent burning of the lawn.
9. To insure uniform coverage, make each pass so that the broadcast pattern slightly overlaps the pattern from the previous pass as shown in figure 19. The approximate broadcast widths for different materials are shown in the *Application Diagram* figure 19.
10. When broadcasting weed control fertilizers, make sure the broadcast pattern does not hit evergreen trees, flowers or shrubs.

IMPORTANT: Application rates shown in the chart are affected by humidity and by the moisture content of the material (granular and pellet). Some minor setting adjustments may be necessary to compensate for this condition.

APPLICATION CHART		
MATERIAL TYPE	FLOW SETTING 3 MPH (100 FT. IN 23 SEC.)	SPREAD WIDTH IN FEET
FERTILIZER		
Powder	3-5	3-4
Granular	3-5	8-10
Pelleted	3-5	10-12
Organic	6-8	6-8
GRASS SEED		
Fine	3-4	6-7
Coarse	4-5	8-9
ICE MELTER	6-8	10-12

OPERATING SPEED - 3 MPH. (100 ft. in 23 seconds)

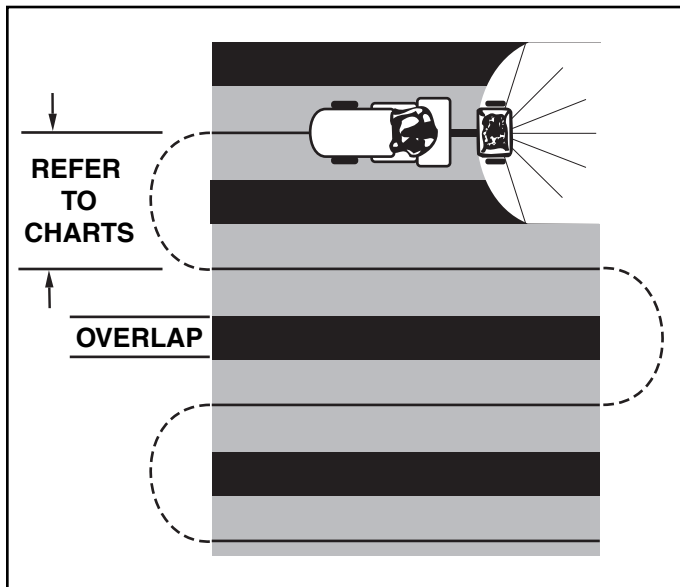

FIGURE 19

MAINTENANCE

CHECK FOR LOOSE FASTENERS

1. Before each use, make a thorough visual check of the spreader for any bolts and nuts which may have loosened. Retighten any loose bolts and nuts.

CHECK FOR WORN OR DAMAGED PARTS

2. Check for worn or damaged parts before each use. Repair or replace parts if necessary.

CHECK TIRE INFLATION

3. Check if tires are adequately inflated before each use. Do not inflate tires beyond maximum recommended pressure.



CAUTION: DO NOT inflate tires beyond the maximum recommended pressure printed on side of tire.

CLEANING

4. Rinse inside of hopper and exterior of spreader and allow to dry before storing.

LUBRICATE (See figure 20)

5. Remove one small and two large hairpins and separate the gearbox housings.
6. Lightly apply automotive grease as needed to the gears.
7. Oil the nylon bushings on the vertical sprocket shaft. Apply grease to the axle at least once a year, or more often as needed.
8. Oil (idler) wheel at least once a year or more often as needed.
9. Install gearbox housings and secure with hairpins.

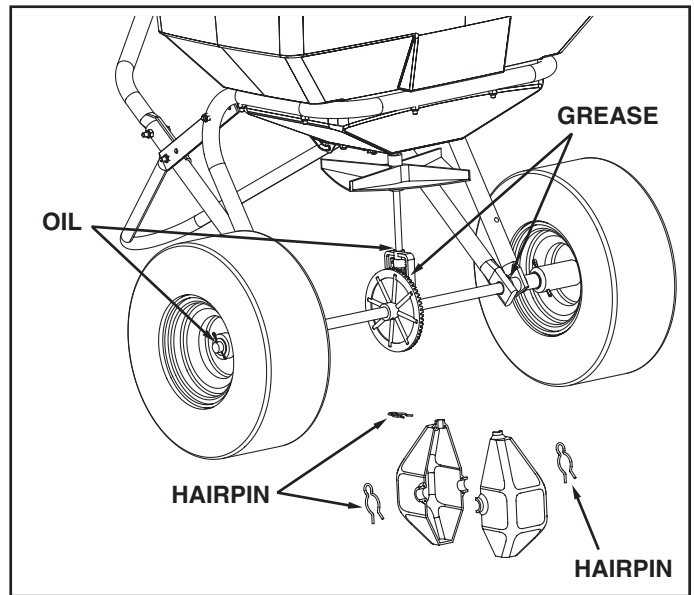

FIGURE 20

STORAGE

1. Rinse inside of hopper and exterior of spreader and allow to dry before storing.
2. Store in a clean, dry area.

SERVICE AND ADJUSTMENTS

1. If the axle and gear assembly is disassembled, mark down the positions of the parts as they are removed. The large gear position in relation to the small gear determines which direction the spreader plate will spin. Be sure to reassemble them in their original positions. (Refer to parts exploded view on page 10). Ensure washer (Refer to item 33 on page 10 and 11) is in place when assembling the axle components. Add grease to gears.
2. If the agitator hairpin becomes damaged or worn, it can be replaced. Remove old agitator hairpin from hole in impeller shaft and replace with new agitator hairpin. See figure 21.

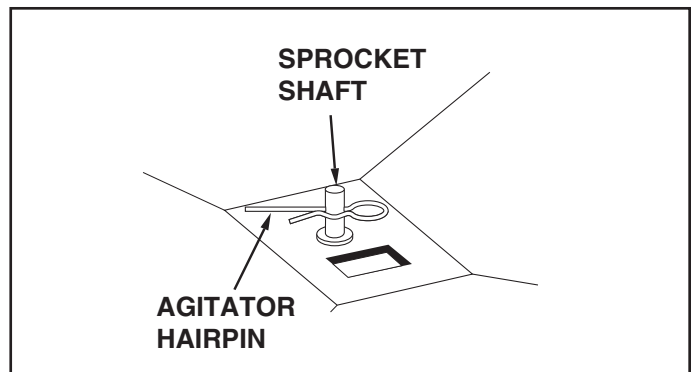
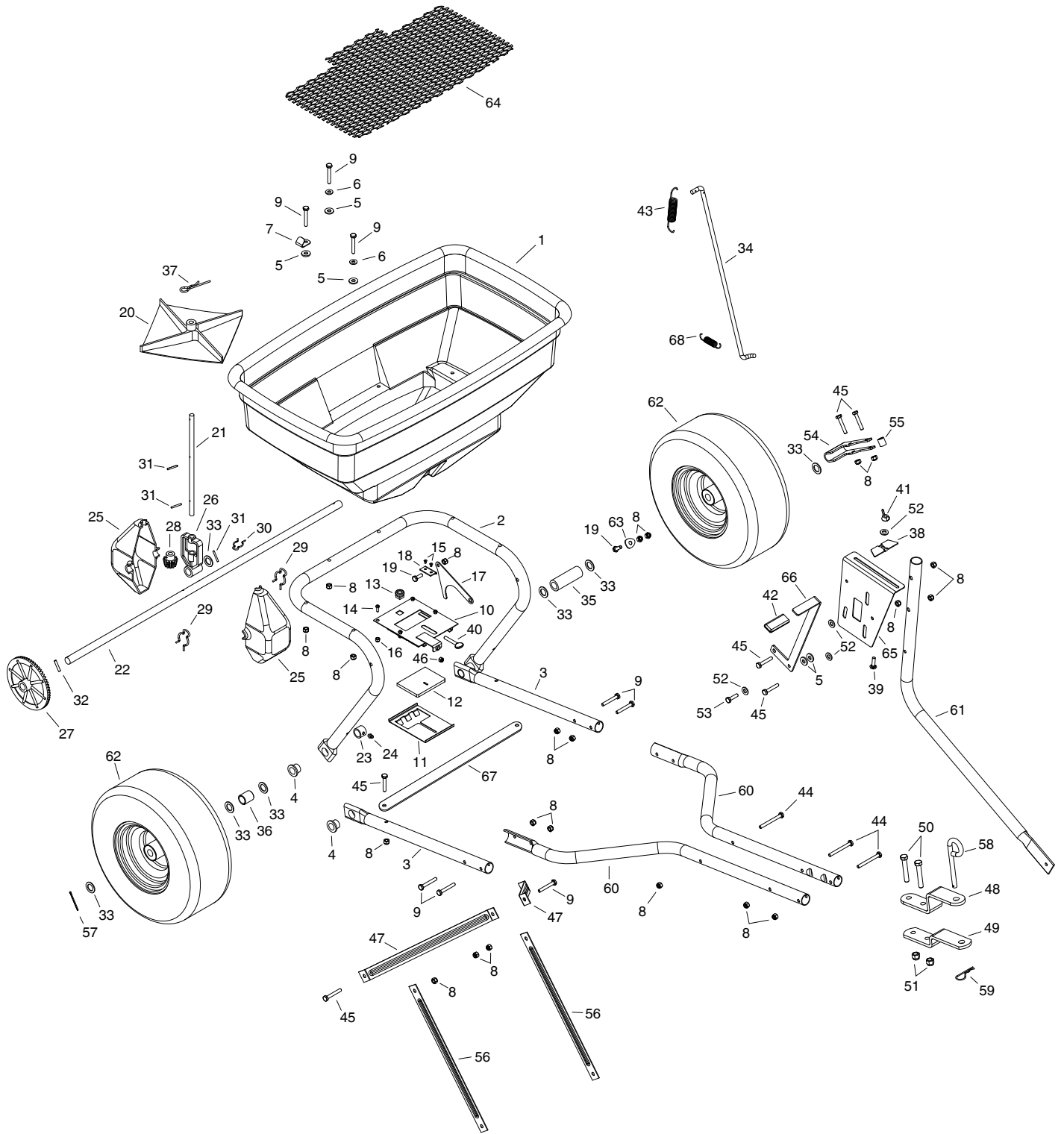

FIGURE 21

REPAIR PARTS FOR BROADCAST SPREADER MODELS 45-0414, 45-0415



REPAIR PARTS FOR BROADCAST SPREADER

MODELS 45-0414, 45-0415

REF.	PART NO.	QTY	DESCRIPTION	REF.	PART NO.	QTY	DESCRIPTION
1	44466	1	Hopper, Spreader (125 lb.)	35	23668	1	Spacer, .64 x 1 x 2.94
2	48842	1	Tube, Frame (45-0414)	36	48857	1	Spacer, .64 x .84 x 1
	48842SS	1	Tube, Frame (45-0415)	37	48934	1	Hairpin, Agitator
3	25755	2	Handle, Lower (45-0414)	38	25763	1	Adjustable Stop
	25755SS	2	Handle Lower (45-0415)	39	49903	1	Carriage Bolt, 1/4-20 x 3/4" *
4	741-0249	4	Bearing, Flanged	40	49931	1	Thumb Screw, 1/4-20 x 1-1/4" *
5	1543-69	8	Washer, Nylon	41	47141	1	Wing Nut, 1/4-20
6	49890	4	Washer, 1/4" *	42	43848	1	Control Arm Grip
7	25672	2	Clip	43	49901	1	Spring
8	49891	27	Nylock Nut, 1/4-20 *	44	49908	3	Hex Bolt, 1/4-20 x 2-1/2" *
9	49892	11	Hex Bolt, 1/4-20 x 1-3/4" *	45	49909	8	Hex Bolt, 1/4-20 x 1-1/2" *
10	65457	1	Closure Guide	46	40520	1	Nylon Nut
11	25757	1	Plate, Pattern	47	23525	2	Hitch Brace (bent)
12	23533	1	Plate, Closure	48	23014	1	Hitch Bracket
13	44285	1	Bushing, Hopper Bottom	49	23687	1	Hitch Bracket
14	49894	4	Slot Truss Bolt, 10-32 x 1/2" *	50	40305	2	Hex Bolt, 3/8-16 x 2-1/4" *
15	43882	2	Pop Rivet, 3/16 *	51	40306	2	Nylock Nut, 3/8-16 *
16	49895	4	Nylock Nut, 10-32 *	52	40308	4	Washer, .3437 x .6875 *
17	25758	1	Link, Flow Control	53	40310	1	Hex Bolt, 1/4-20 x 1" *
18	25917	1	Slide Gate Angle Bracket	54	26026	1	Engagement Bracket
19	40199	2	Hex Bolt, 1/4-20 x 3/4" *	55	23658	1	Spacer, .39 x .56 x .62
20	04367	1	Spreader Impeller	56	26023	2	Hitch Brace (straight)
21	49896	1	Shaft, Impeller	57	49911	1	Cotter Pin, 9/64 x 1-1/2" *
22	26027	1	Axle	58	23353	1	Hitch Pin, 3/8 x 3"
23	49910	2	Spacer, Axle Tube	59	43343	1	Hair Cotter Pin, 3/32 x 2-5/16"
24	49798	2	Fitting, Grease 1/4"	60	40291	2	Drawbar Tube (45-0414)
25	47212	2	Housing, Large Gear		40291SS	2	Drawbar Tube (45-0415)
26	47204	1	Yoke, Large	61	40292	1	Control Tube (45-0414)
27	47209	1	Gear, Large		40292SS	1	Control Tube (45-0415)
28	47205	1	Gear, Small	62	40355	2	Wheel
29	49897	2	Clip, Hairpin 7/8	63	44695	1	Bowed Washer
30	49898	1	Clip, Hairpin 5/8	64	47441	1	Spreader Screen
31	46055	3	Pin, Spring 1/8 x 1"	65	24915	1	Flow Control Bracket
32	43659	1	Pin, Spring 3/16 x 1"	66	26004	1	Control Arm
33	49899	7	Washer	67	26142	1	Cross Frame Strap
34	40304	1	Rod, Flow Control	68	40526	1	Spring
					40454	1	Owners Manual

* Stainless Steel Fastener

SpeedPart *the fastest way to purchase parts* www.speedepart.com

SpeedPart *the fastest way to purchase parts* www.speedepart.com

REPAIR PARTS

Agri-Fab, Inc.
809 South Hamilton
Sullivan, IL. 61951
217-728-8388
www.agri-fab.com